

## Stainless Steel 2-Piece Ball Valve

### Features

- Flanged PN16/40
- ISO 5211 Direct Mount
- TFM1600 Seats
- PN40 Rated (1/2" to 2")
- PN16 Rated (2 1/2" to 6")
- Full Bore
- PTFE Seals

### Pressure / Temperature

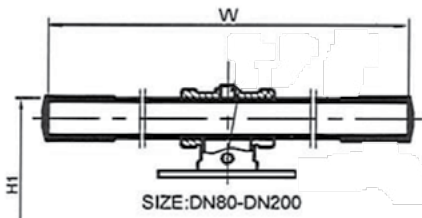
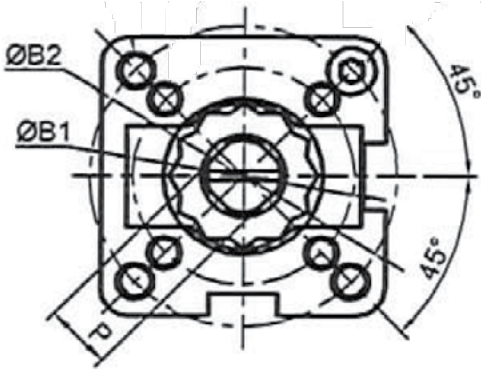
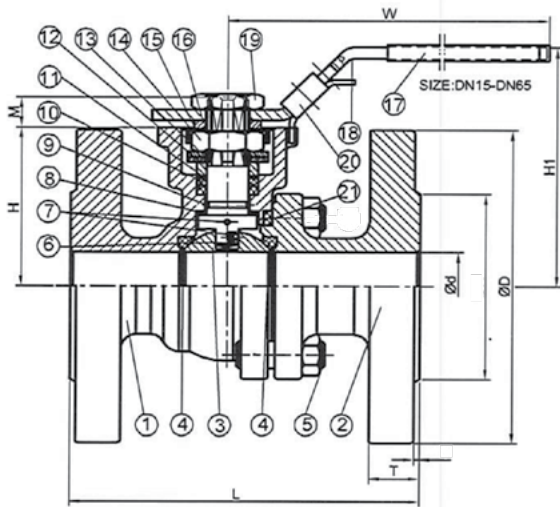
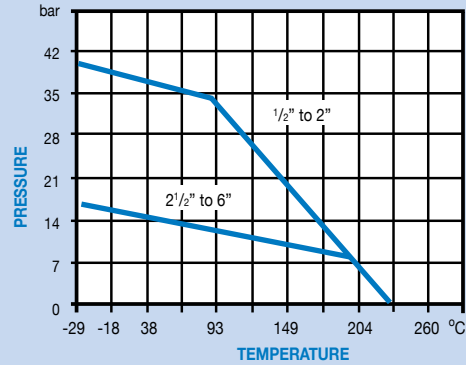

Torque includes 25% safety calculated at 16 bar water. For high pressure and viscous media contact the sales office for advice.

### Technical Data

Maximum Pressure 16 Bar (2 1/2"-6") 40 Bar (1/2"-2")  
 Working Temperature -29°C to +230°C

N.	Part Name	Materials
1	Body	ASTM A351-CF8M
2	End Cap	ASTM A351-CF8M
3	Ball	ASTM A351-CF8M
4	Ball Seat	TFM 1600
5	Bolting	AISI 304
6	Stem	AISI 316
7	Anti-static Device	AISI 316
8	Thrust Washer	PTFE
9	O-Ring	FPM(VITON)
10	Stem Packing	PTFE
11	Bushing	50%SS+50%PTFE
12	Gland	AISI 316
13	Belleville Washer	S301
14	Stem Nut	AISI 304 A2-70
15	Stop-lock-Cap	AISI 304
16	Handle Gland	AISI 304
17	Handle Sleeve (DN15-DN65)	VINYL PLASTIC
18	Handle (DN15-DN65)	AISI 304
19	Handle Nut (DN15-DN65)	AISI 304
20	Lock Device (DN15-DN65)	AISI 304
21	Body Gasket	PTFE

DN	1/2"	3/4"	1"	1 1/4"	1 1/2"	2"	2 1/2"	3"	4"	5"	6"
D	15.0	20.0	25.0	32.0	38.0	50.0	63.5	76.0	100.0	125.0	150.0
L	115.0	120.0	125.0	130.0	140.0	150.0	170.0	180.0	190.0	325.0	350.0
øD	95.0	105.0	115.0	140.0	150.0	165.0	185.0	200.0	220.0	250.0	285.0
T	16.0	18.0	18.0	18.0	18.0	20.0	18.0	20.0	20.0	22.0	22.0
H	48.0	53.0	58.5	71.0	76.0	85.0	101.5	111.5	140.0	183.0	204.0
H1	78.0	84.0	89.3	101.0	107.0	116.0	150.0	176.0	205	255.5	275.0
M	9.0	9.0	11.0	11.0	14.0	14.0	17.0	17.0	22.0	27.0	27.0
P	9.0	9.0	11.0	11.0	14.0	14.0	17.0	17.0	22.0	27.0	27.0
B1	F03	F03	F04	F04	F05	F05	F07	F07		F12	F12
B2	F04	F04	F05	F05	F07	F07	F10	F10			
W	145.0	145.0	175.0	175.0	190.0	190.0	265	300	400	600	800
Torque	6	10	15	21	36	45	61	118	190	306	425
Kgs	2.4	3.2	4.1	5.6	6.7	9.7	13.9	18.2	25.6	51	72.5

Dimensions in mm

This data sheet is designed as a guide and should not be regarded as wholly accurate in every detail. We reserve the right to amend the specification of any product without notice.